

WINDLOCH, LLC

COMPUTER SIMULATION REPORT

SCOPE OF WORK

MINIMAL 52 SLIDING DOOR - NFRC 100/200/500

REPORT NUMBER

P4680.01-116-45 R0

TEST DATE

11/22/22

ISSUE DATE

11/22/22

PAGES

12

DOCUMENT CONTROL NUMBER

RT-R-AMER-Test-4044 (04/11/22)

©2017 INTERTEK

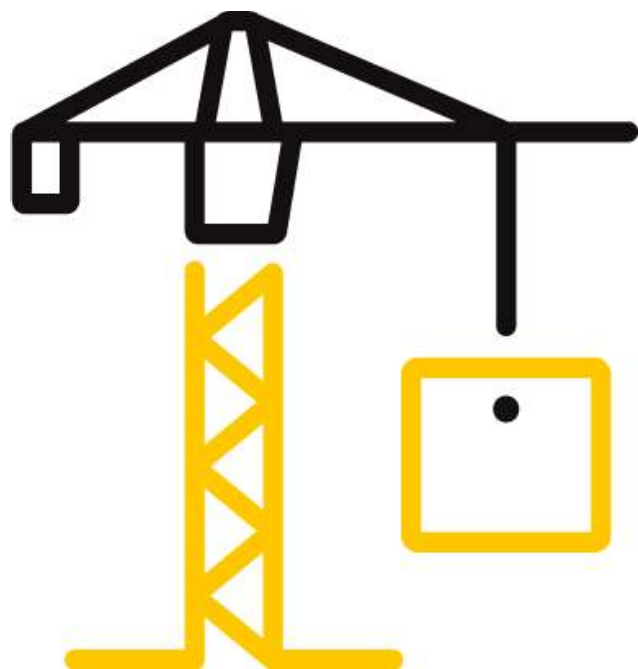

TEST REPORT FOR WINDLOCH, LLC

Report No: P4680.01-116-45 R0

Date: 11/22/22

REPORT ISSUED TO

WINDLOCH, LLC

467 Brook Avenue

Deer Park, New York 11729

SECTION 1

SUMMARY

SERIES/MODEL: Minimal 52 Sliding Door

Architectural Testing, Inc. (an Intertek company) dba Intertek Building & Construction (B&C) was contracted to perform U-Factor, Solar Heat Gain Coefficient, Visible Transmittance and Condensation Resistance simulations in accordance with the National Fenestration Rating Council (NFRC).

This report does not constitute certification of this product nor an opinion or endorsement by this laboratory. Intertek B&C will service this report for the entire test record retention period. The test record retention period ends five years after the test date. Test records, such as detailed drawings, datasheets, representative samples of test specimens, or other pertinent project documentation, will be retained for the entire test record retention period.

FOR INTERTEK B&C:

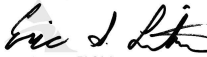
COMPLETED BY: Eric S. Leitner
Manager - Thermal
TITLE: Testing & Simulations
SIGNATURE: 
Digitally Signed by: Eric S. Leitner
DATE: 11/22/22

REVIEWED BY: Jonathan P. Spencer
TITLE: Project Engineer
SIGNATURE: 
Digitally Signed by: Jonathan Spencer
DATE: 11/22/22

ESL:esl

This report is for the exclusive use of Intertek's Client and is provided pursuant to the agreement between Intertek and its Client. Intertek's responsibility and liability are limited to the terms and conditions of the agreement. Intertek assumes no liability to any party, other than to the Client in accordance with the agreement, for any loss, expense or damage occasioned by the use of this report. Only the Client is authorized to permit copying or distribution of this report and then only in its entirety. Any use of the Intertek name or one of its marks for the sale or advertisement of the tested material, product or service must first be approved in writing by Intertek. The observations and test results in this report are relevant only to the sample(s) tested. This report by itself does not imply that the material, product, or service is or has ever been under an Intertek certification program.

TEST REPORT FOR WINDLOCH, LLC

Report No: P4680.01-116-45 R0

Date: 11/22/22

SECTION 2

TEST METHODS

The products were evaluated in accordance with the following:

ANSI/NFRC 100-2020, Procedure for Determining Fenestration Product U-Factors

ANSI/NFRC 200-2020, Procedure for Determining Fenestration Product Solar Heat Gain Coefficient and Visible Transmittance at Normal Incidence

NFRC 500-2017, Procedure for Determining Fenestration Product Condensation Resistance Values

**Condensation Resistance results obtained from this procedure are for controlled laboratory conditions and do not include the effects of air movement through the specimen, solar radiation, and the thermal bridging that may occur due to the specific design and construction of the fenestration system opening.*

Ratings values included in this report are for submittals to an NFRC-licensed IA and are not meant to be used directly for labeling purposes. Only those values identified on a valid Certificate of Authorization (CA) by an NFRC accredited Inspection Agency (IA) are to be used for labeling purposes. The ratings values were rounded in accordance with NFRC 601, NFRC Unit and Measurement Policy.

Intertek B&C is an NFRC accredited simulation laboratory and all simulations were conducted in full compliance with NFRC approved procedures and specifications. The values included in this report are not considered in compliance with ANSI/NFRC 100, ANSI/NFRC 200, and/or NFRC 500 unless the associated validation test requirements have been satisfied, as applicable.

TEST REPORT FOR WINDLOCH, LLC

Report No: P4680.01-116-45 R0

Date: 11/22/22

SECTION 3

TEST PROCEDURE

The total product, including specific frame, spacer, and glass details, was modeled using NFRC approved software.

FRAME AND EDGE MODELING	THERM 7.4.4
CENTER-OF-GLASS MODELING	WINDOW 7.4.14
TOTAL PRODUCT CALCULATIONS	WINDOW 7.4.14
SPECTRAL DATA LIBRARY	IGDB 88.0

Modeling Assumptions / Technical Interpretations

Any modeling assumptions and technical interpretations required to model this product are listed below.

- 1) To prevent air infiltration, tape was applied to all interior sash crack locations.

SECTION 4

SIMULATION SPECIMEN DESCRIPTION

SERIES/MODEL	Minimal 52 Sliding Door
PRODUCT TYPE	Sliding Glass Door
FRAME MATERIAL	AT - Aluminum w/ Thermal Breaks - All Members
SASH MATERIAL	AT - Aluminum w/ Thermal Breaks - All Members
STANDARD SIZE	4000mm x 3048mm

TEST REPORT FOR WINDLOCH, LLC

Report No: P4680.01-116-45 R0

Date: 11/22/22

SECTION 4 (Continued)

SIMULATION SPECIMEN DESCRIPTION

SPACER OPTIONS			
TYPE	PRIMARY SEAL	SECONDARY SEAL	CODE
Technoform Spacer	PIB	Silicone	TS-D

GRID OPTIONS		
GRID SIZE	GRID TYPE	GRID PATTERN
None	-	-

REINFORCEMENT OPTIONS	
LOCATION	MATERIAL
None	-

GAS FILLING TECHNIQUE	
FILL TYPE	METHOD
90% Argon	Single probe

EDGE-OF-GLASS CONSTRUCTION	
INTERIOR CONDITION	EPDM gasket between glazing bead and glass
EXTERIOR CONDITION	EPDM gasket between sash leg and glass

WEATHERSTRIPPING		
TYPE	QUANTITY	LOCATION
Finpile	2 rows	Frame perimeter
EPDM gasket	2 rows	Interlock

FRAME/SASH MATERIALS FINISH	
INTERIOR	Painted aluminum
EXTERIOR	Painted aluminum

VALIDATION MATRIX*	
PRODUCT LINE	REPORT NUMBER
None	-

*These products are part of a validation matrix. Only one is required for validation testing.

TEST REPORT FOR WINDLOCH, LLC

Report No: P4680.01-116-45 R0

Date: 11/22/22

SECTION 5

SPECIALTY PRODUCTS TABLE

The specialty products method allows the manufacturer to determine the overall product SHGC and VT for any glazing option. The center of glass SHGC and/or VT must be determined using WINDOW 7.4.14. The method calculates overall product SHGC and VT indexed on center of glass properties. All values used in the calculations are truncated to six decimal place precision.

	No Dividers	Dividers < 1	Dividers > 1
SHGC0	0.006749	0.010061	0.013157
SHGC1	0.828467	0.731425	0.640700
VT0	0.000000	0.000000	0.000000
VT1	0.821717	0.721364	0.627543

$$SHGC = SHGC0 + SHGCc (SHGC1 - SHGC0)$$

$$VT = VT0 + VTc (VT1 - VT0)$$

TEST REPORT FOR WINDLOCH, LLC

Report No: P4680.01-116-45 R0

Date: 11/22/22

SECTION 6

SIMULATION RESULTS

TOTAL PRODUCT CALCULATIONS (Minimal 52 Sliding Door)												
Option Number	Pane Thickness 1 (in)	Gap Width 1 (in)	Pane Thickness 2 (in)	Gap Width 2 (in)	Pane Thickness 3 (in)	Gap Width 3 (in)	Pane Thickness 4 (in)	Gap Fill	Low-e (Surface #)	Tint	Spacer	Grid Type
	U-Factor (Btu/Hr-Ft ² -F)		Solar Heat Gain Coefficient (SHGC) Grids (None / <1 / >=1)				Visible Transmittance (VT) Grids (None / <1 / >=1)		Condensation Resistance (CR)			
1	GL1: SB72 (#2) on Acuity / arg / Acuity (6mm/6mm) - 25mm IG											
	0.223	0.563	0.223					ARG90	0.018(#2)	CL	TS-D	N
	U-Factor	0.31	SHGC(N)	0.249	VT(N)	0.601	CR	51.5				

TEST REPORT FOR WINDLOCH, LLC

Report No: P4680.01-116-45 R0

Date: 11/22/22

SECTION 7

DRAWINGS / BILL OF MATERIALS

The drawings which follow have been reviewed by Intertek B&C and are representative of the simulation results reported herein. Any deviations are documented herein or on the drawings.

At the time of simulation, dimensioned part drawings were not available and could not be verified.

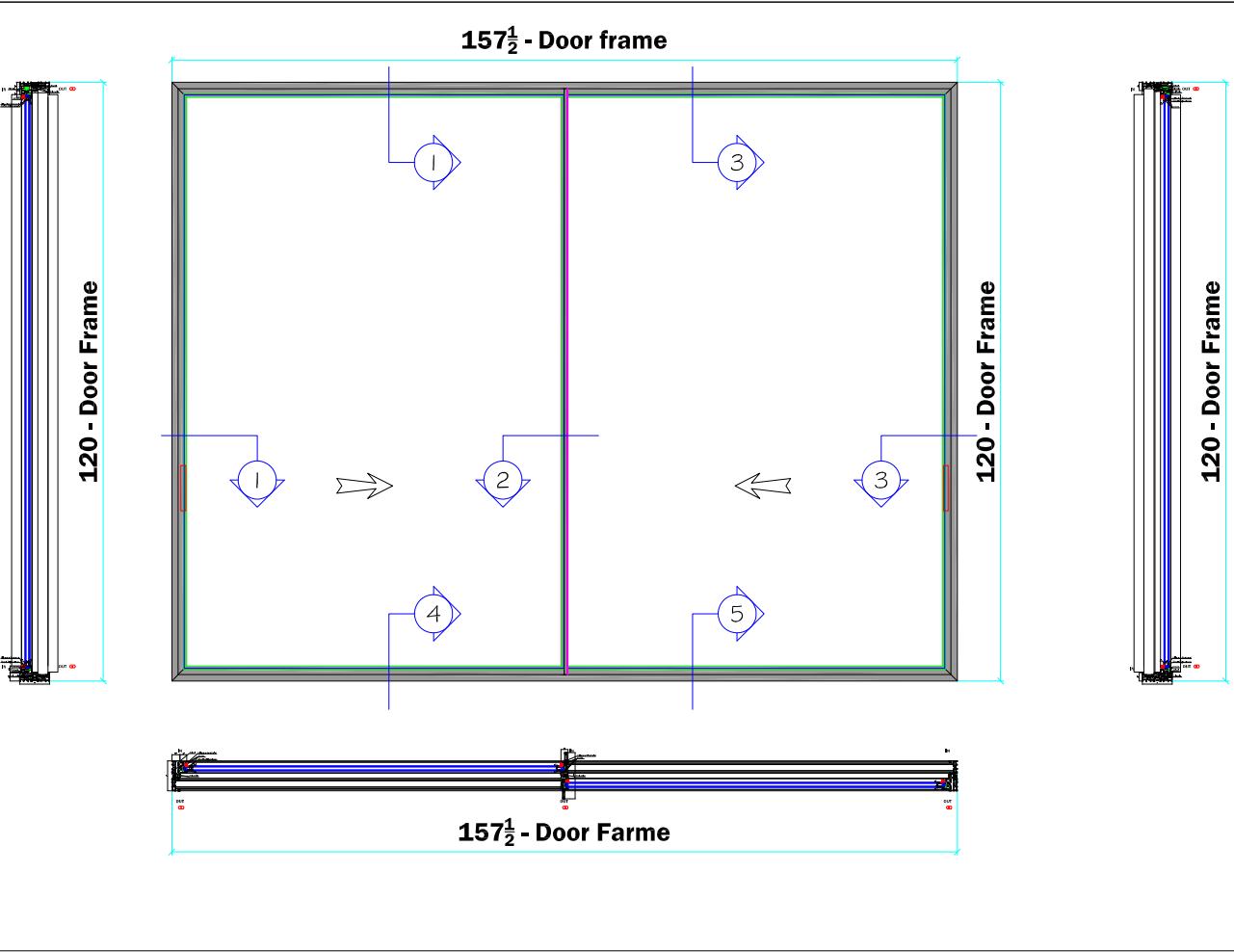

General Notes:

Profiles: Aluminum 6063-T6

Glass:

Option 1:

Outer pane: $\frac{1}{4}$ Solarban 72#2 on Acuity

Spacer: $\frac{9}{16}$ Warm edge with Argon

Inner pane: $\frac{1}{4}$ Acuity

Option 2:

Outer pane: $\frac{1}{4}$ Solarban 60#2 on Clear

Spacer: $\frac{9}{16}$ Warm edge with Argon

Inner pane: $\frac{1}{4}$ Clear

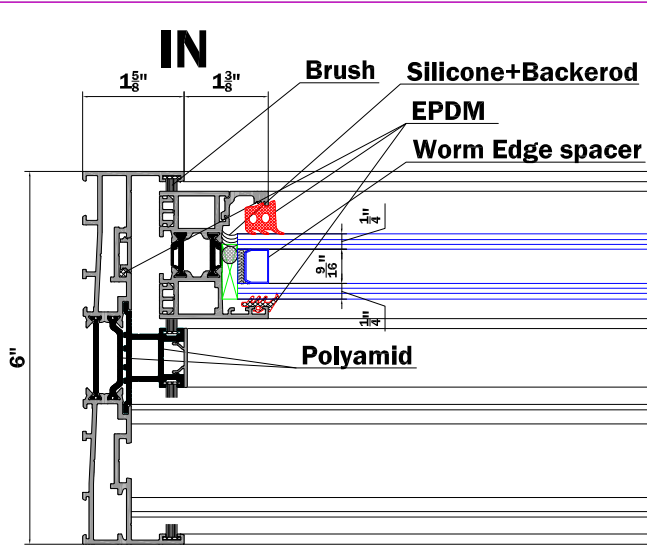

 Report #: P4680-116-45
 Date: 11/22/2022
 Verified by: *[Signature]*

 WINDLOCH 467 Brook Avenue, Unit-C Deer Park, NY 11729 (718)940-8331 (831)940-7745 (941)718-4868 Fax info@windloch.com WWW.WINDLOCH.COM	THESE SHOP DRAWINGS CONTAIN PROPRIETARY INFORMATION OF WINDLOCH LLC. THEY ARE INTENDED SOLELY FOR THE INFORMATION AND USE OF WINDLOCH LLC, AND THE PARTIES MENTIONED HEREIN. SUCH PROPRIETARY INFORMATION MAY NOT BE USED, REPRODUCED OR DISCLOSED TO ANY OTHER PARTIES WITHOUT THE EXPRESSED PERMISSION OF WINDLOCH LLC.	
	PROJECT: YOAV BEN-SHIMON LOCATION: 1/2"=1' (11x17) ARCHITECT: 11/22/22 CONSULTANT: SHEET DESCRIPTION: Sliding Door Minimal 52	DRAWN BY: YOAV BEN-SHIMON SCALE: DATE: SHEET NO.: 101

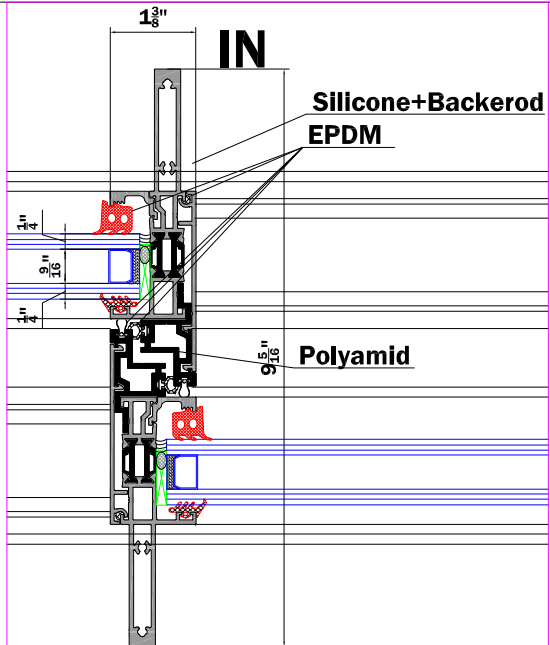

OUT

1



OUT

2

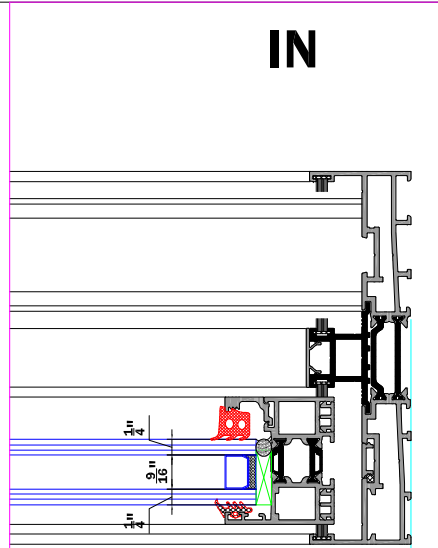

OUT

3

 Report #: P4680-116-45
Date: 11/22/2022
Verified by: *[Signature]*

 **WINDLOCH**

467 Brook Avenue, Unit-C
Deer Park, NY 11729
(718)940-8391
(831)940-7745
(941)718-4868 Fax
Info@windloch.com
WWW.WINDLOCH.COM

THESE SHOP DRAWINGS CONTAIN PROPRIETARY INFORMATION OF WINDLOCH LLC. THEY ARE INTENDED SOLELY FOR THE INFORMATION AND USE OF WINDLOCH LLC, AND THE PARTIES MENTIONED HEREIN. SUCH PROPRIETARY INFORMATION MAY NOT BE USED, REPRODUCED OR DISCLOSED TO ANY OTHER PARTIES WITHOUT THE EXPRESSED PERMISSION OF WINDLOCH LLC.

REV.	DESCRIPTION	BY	DATE

PROJECT:	YOAV BEN-SHIMON
LOCATION:	SCALE:
ARCHITECT:	6"=1' (11x17)
CONSULTANT:	DATE:
	11/22/22
SHEET DESCRIPTION:	SHEET NO.:
Sliding Door Minimal 52	401

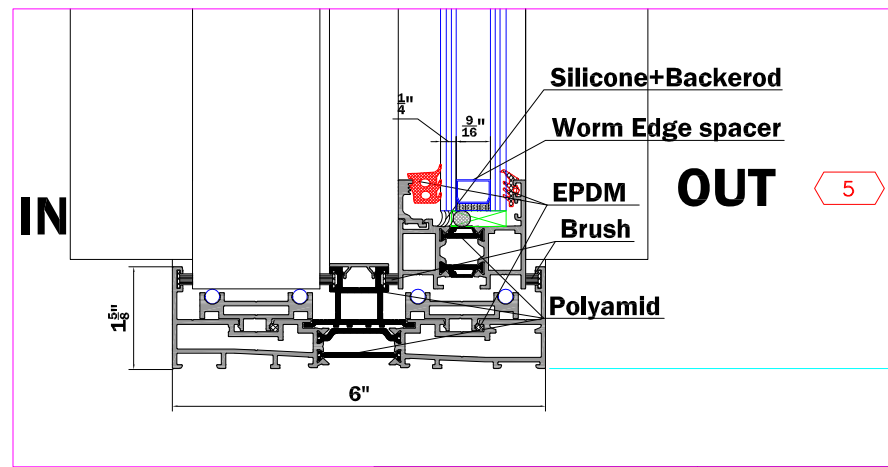
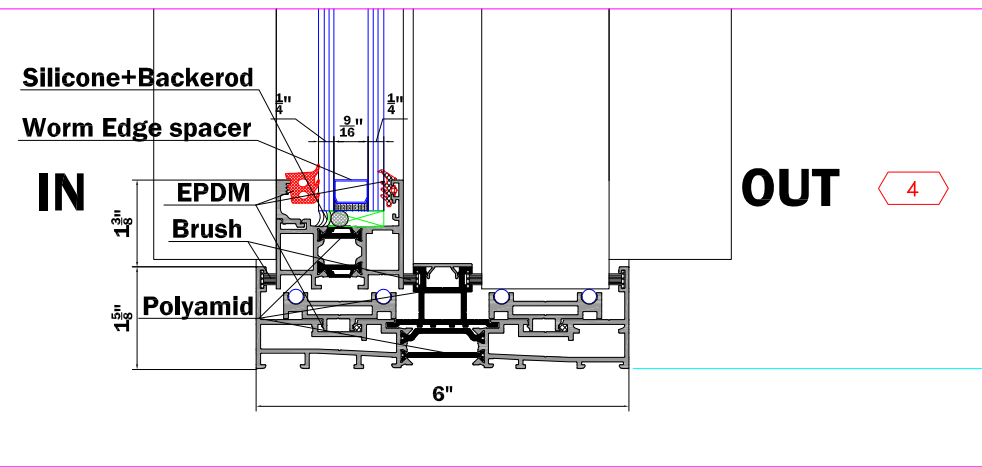
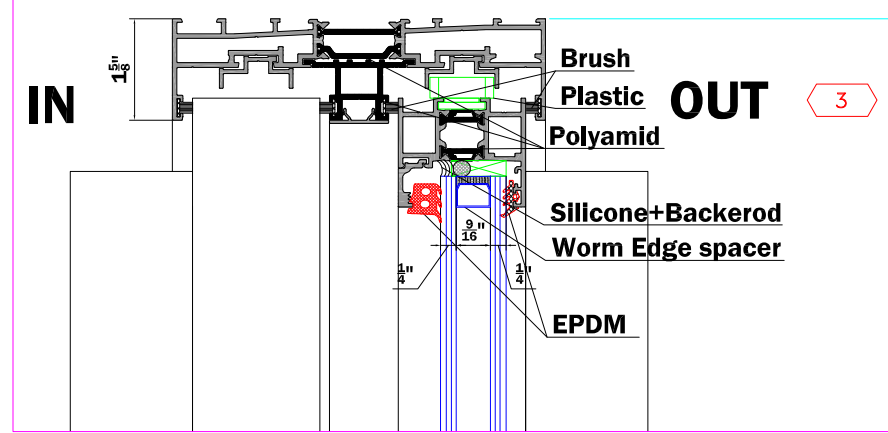
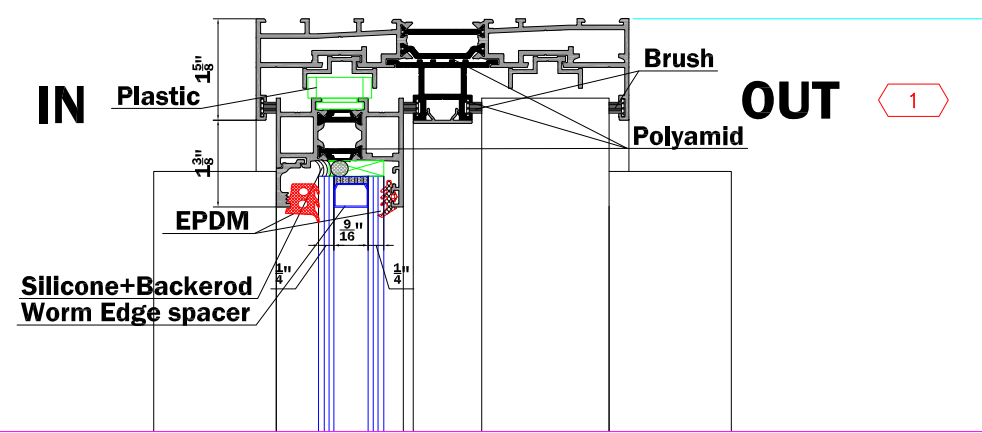

WINDLOCH

467 Brook Avenue, Unit-C
Deer Park, NY 11729
(718)940-8391
(631)940-7745
(941)718-4868 Fax
Info@windloch.com
WWW.WINDLOCH.COM

THESE SHOP DRAWINGS CONTAIN PROPRIETARY INFORMATION OF WINDLOCH LLC. THEY ARE INTENDED SOLELY FOR THE INFORMATION AND USE OF WINDLOCH LLC, AND THE PARTIES MENTIONED HEREIN. SUCH PROPRIETARY INFORMATION MAY NOT BE USED, REPRODUCED OR DISCLOSED TO ANY OTHER PARTIES WITHOUT THE EXPRESSED PERMISSION OF WINDLOCH LLC.

REV.	DESCRIPTION	BY	DATE

PROJECT:	YOAV BEN-SHIMON
LOCATION:	SCALE:
ARCHITECT:	6"=1' (11x17)
CONSULTANT:	DATE:
	11/22/22
SHEET DESCRIPTION:	SHEET NO.:
Sliding Door Minimal 52	402



Total Quality. Assured.

130 Derry Court
York, Pennsylvania 17406

Telephone: 717-764-7700
Facsimile: 717-764-4129
www.intertek.com/building

TEST REPORT FOR WINDLOCH, LLC

Report No: P4680.01-116-45 R0

Date: 11/22/22

SECTION 8

REVISION LOG

REVISION #	DATE	PAGES	REVISION
.01 R0	11/22/22	N/A	Original report issue.

WINDLOCH, LLC

COMPUTER SIMULATION REPORT

SCOPE OF WORK

MINIMAL 52 SLIDING DOOR - CUSTOM COMPUTER SIMULATIONS TO DETERMINE INTERIOR SURFACE CONDENSATION

REPORT NUMBER

P4680.03-116-45 R0

TEST DATE

11/22/22

ISSUE DATE

11/22/22

PAGES

25

DOCUMENT CONTROL NUMBER

RT-R-AMER-Test-3751 (01/13/22)

©2017 INTERTEK

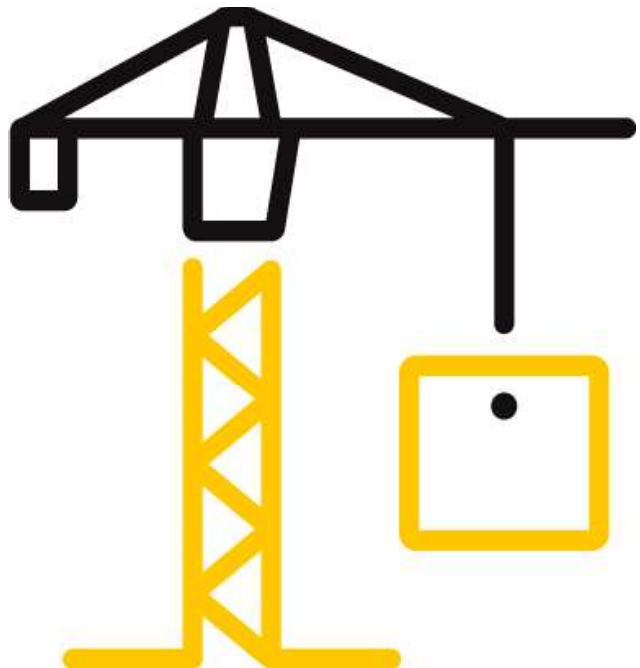

TEST REPORT FOR WINDLOCH, LLC

Report No.: P4680.03-116-45 R0

Date: 11/22/22

REPORT ISSUED TO

WINDLOCH, LLC

467 Brook Avenue

Deer Park, New York 11729

SECTION 1

SUMMARY

SERIES/MODEL: Minimal 52 Sliding Door

Architectural Testing, Inc. (an Intertek company), dba Intertek Building & Construction (Intertek B&C), was contracted to perform custom computer simulations utilizing thermal modeling computer software developed by Lawrence Berkeley National Laboratory (LBNL). Results obtained are simulated values and were secured using the designated test methods.

This report is prepared for research and informational purposes only. These results are only a guide to the actual system performance and should not be interpreted as exact performance. This analysis is performed at ideal steady-state conditions and does not account for any outside influences, three-dimensional interactions, or final installation of the system in the field.

This report does not constitute certification of this product nor an opinion or endorsement by this laboratory. Intertek B&C will service this report for the entire test record retention period. The test record retention period ends four years after the test date.

For INTERTEK B&C:

COMPLETED BY:	Eric S. Leitner
TITLE:	Manager - Simulations & Thermal Testing, SIRC
SIGNATURE:	 <small>Digitally Signed by: Eric S. Leitner</small>
DATE:	11/22/22

REVIEWED BY:	Jonathan P. Spencer
TITLE:	Project Engineer
SIGNATURE:	 <small>Digitally Signed by: Jonathan Spencer</small>
DATE:	11/22/22

ESL:esl

This report is for the exclusive use of Intertek's Client and is provided pursuant to the agreement between Intertek and its Client. Intertek's responsibility and liability are limited to the terms and conditions of the agreement. Intertek assumes no liability to any party, other than to the Client in accordance with the agreement, for any loss, expense or damage occasioned by the use of this report. Only the Client is authorized to permit copying or distribution of this report and then only in its entirety. Any use of the Intertek name or one of its marks for the sale or advertisement of the tested material, product or service must first be approved in writing by Intertek. The observations and test results in this report are relevant only to the sample(s) tested. This report by itself does not imply that the material, product, or service is or has ever been under an Intertek certification program.

TEST REPORT FOR WINDLOCH, LLC

Report No.: P4680.03-116-45 R0

Date: 11/22/22

SECTION 2

TEST METHODS

The products were evaluated in general accordance with the following:

THERM 7 / WINDOW 7 NFRC Simulation Manual

THERM 7.4, This program calculates heat loss through frame and edge-of-glass components using finite difference analysis. The program solves for temperature and heat flow distribution throughout the cross section. The temperature distribution can then be used to determine overall heat loss, total and component U-Factors, and local temperatures at points of interest.

WINDOW 7.4, This program calculates U-Factor and center-of-glazing (COG) temperatures using a two-dimensional heat flow analysis.

SECTION 3

TEST PROCEDURE

The total product, including specific frame, spacer and glass details, was modeled using NFRC approved software.

FRAME AND EDGE MODELING	THERM 7.4.4
CENTER-OF-GLASS MODELING	WINDOW 7.4.14
TOTAL PRODUCT CALCULATIONS	WINDOW 7.4.14
SPECTRAL DATA LIBRARY	IGDB 88.0

Modeling Assumptions / Technical Interpretations

Any modeling assumptions and technical interpretations required to model this product are listed below.

- 1) To prevent air infiltration, tape was applied to all interior sash crack locations.
- 2) Models were constructed at ideal conditions. Hardware, fasteners, and weep holes were not modeled.

TEST REPORT FOR WINDLOCH, LLC

Report No.: P4680.03-116-45 R0

Date: 11/22/22

SECTION 4

SIMULATION SPECIMEN DESCRIPTION

SERIES/MODEL	Minimal 52 Sliding Door
FRAME MATERIAL	AT - Aluminum w/ Thermal Breaks - All Members
SASH MATERIAL	AT - Aluminum w/ Thermal Breaks - All Members

GLAZING OPTIONS				
	OUTER PANE	GAP SIZE	GAP FILL	INNER PANE
GL1	6mm SB72 (#2) on Acuity	0.563	90% Argon	6mm Acuity
GL2	6mm SB60 (#2) on Clear	0.563	90% Argon	6mm Clear

SPACER OPTIONS				
	TYPE	PRIMARY SEAL	SECONDARY SEAL	CODE
	Technoform Spacer	PIB	Silicone	TS-D

SECTION 5

MEASURED SIMULATION DATA

DEWPOINT TEMPERATURE ANALYSIS†	
Exterior Air Temperature	0°F
Interior Air Temperature	70°F
Relative Humidity	30% RH
Exterior Wind Velocity	12.3 mph

†Dewpoint temperature criteria per Windloch, LLC

TEST REPORT FOR WINDLOCH, LLC

Report No.: P4680.03-116-45 R0

Date: 11/22/22

SECTION 6

SIMULATION RESULTS

DEWPOINT TEMPERATURE ANALYSIS

The component parts of the system were modeled at the specified conditions to determine the coldest temperature on the interior surface of each section. The coldest temperature can be compared with the dewpoint at the specified temperatures to determine the probability of condensation.

Cross Section Description	Section Coldest Temperature	Dewpoint Temperature
1/401	34.1°F	37.2°F
2/401	15.3°F	37.2°F
3/401	30.6°F	37.2°F
1/402	40.3°F	37.2°F
3/402	34.0°F	37.2°F
4/402	36.0°F	37.2°F
5/402	33.3°F	37.2°F

TEST REPORT FOR WINDLOCH, LLC

Report No.: P4680.03-116-45 R0

Date: 11/22/22

SECTION 6

SIMULATION RESULTS

DEWPOINT TEMPERATURE ANALYSIS: TEMPERATURE DISTRIBUTION PLOT

Cross Section	1/401
Exterior Air Temperature	0°F
Interior Air Temperature	70°F
Relative Humidity	30% RH
Exterior Wind Velocity	12.3 mph

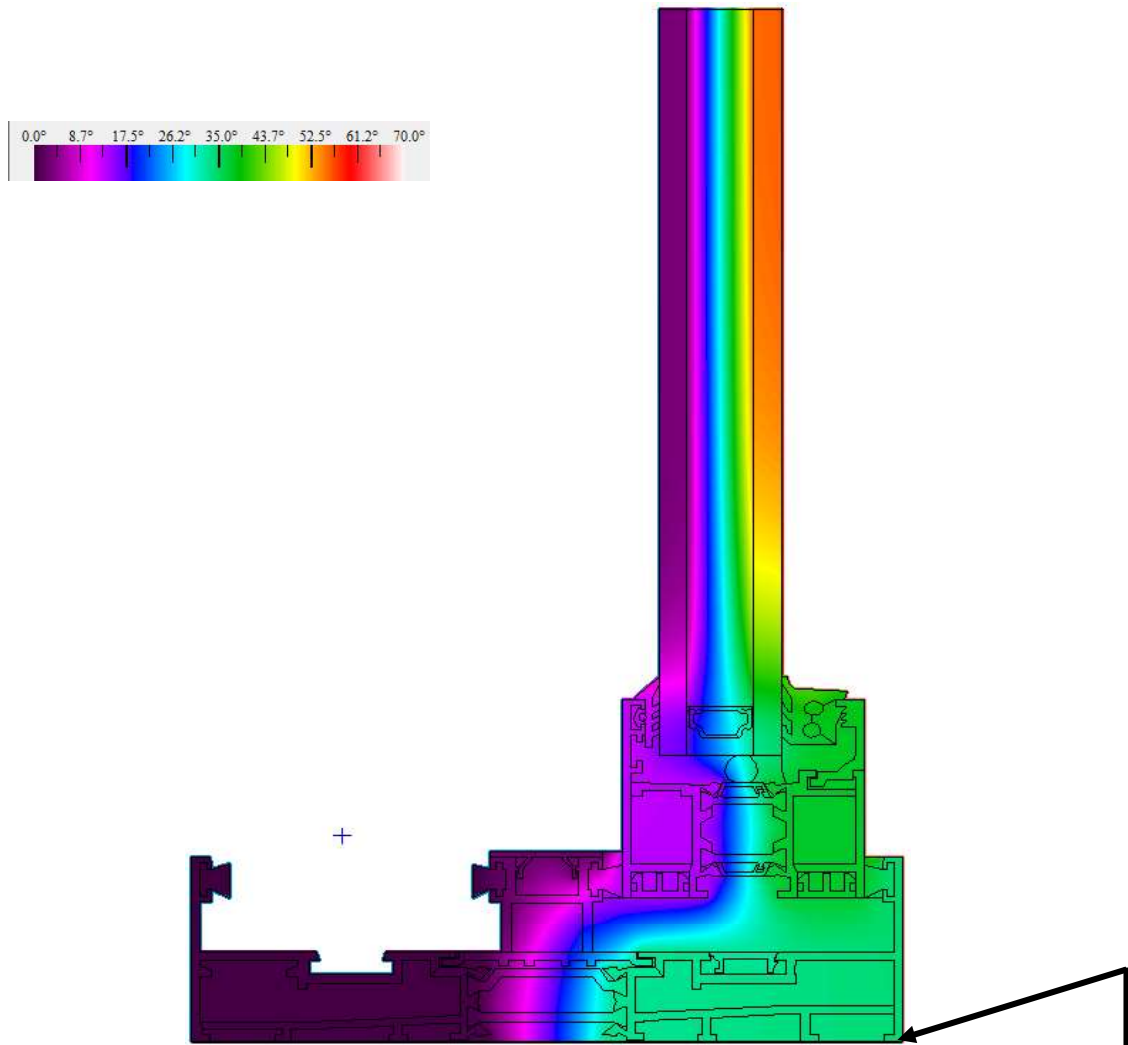

Dewpoint Temperature	37.2°F
Coldest Interior Frame Temperature	34.1°F
Edge of Glass Temperature	46.7°F
Coldest Interior Temperature	34.1°F

TEST REPORT FOR WINDLOCH, LLC

Report No.: P4680.03-116-45 R0

Date: 11/22/22

SECTION 6

SIMULATION RESULTS

DEWPOINT TEMPERATURE ANALYSIS: DEWPOINT LINE PLOT

Cross Section	1/401
Exterior Air Temperature	0°F
Interior Air Temperature	70°F
Relative Humidity	30% RH
Exterior Wind Velocity	12.3 mph

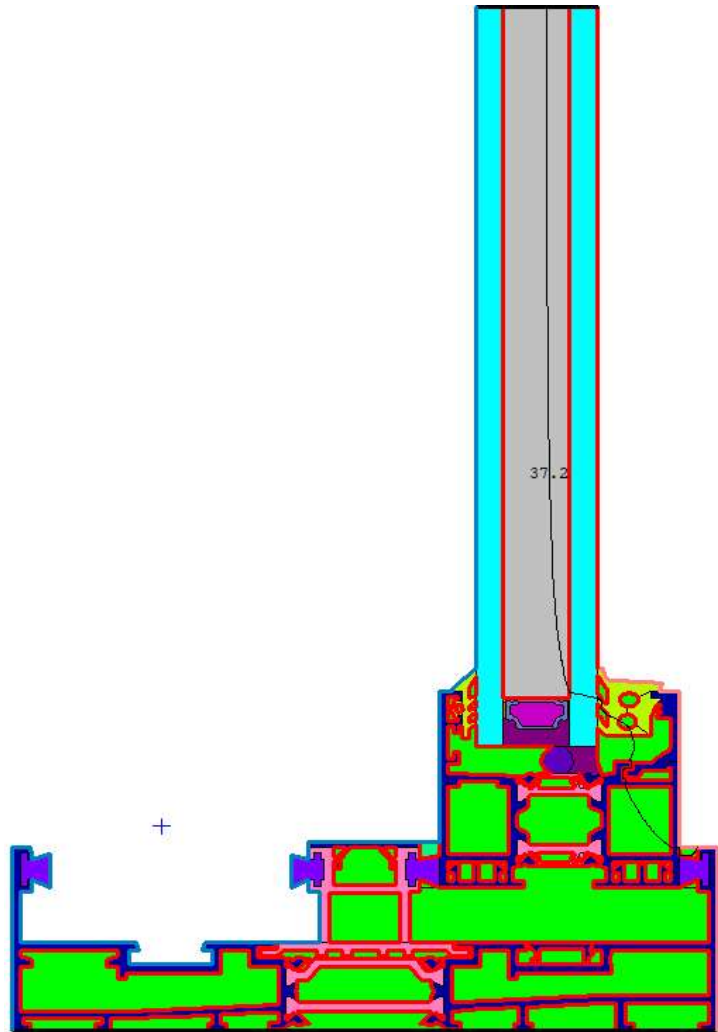

Dewpoint Temperature	37.2°F
Coldest Interior Frame Temperature	34.1°F
Edge of Glass Temperature	46.7°F
Coldest Interior Temperature	34.1°F

TEST REPORT FOR WINDLOCH, LLC

Report No.: P4680.03-116-45 R0

Date: 11/22/22

SECTION 6

SIMULATION RESULTS

DEWPOINT TEMPERATURE ANALYSIS: TEMPERATURE DISTRIBUTION PLOT

Cross Section	2/401
Exterior Air Temperature	0°F
Interior Air Temperature	70°F
Relative Humidity	30% RH
Exterior Wind Velocity	12.3 mph

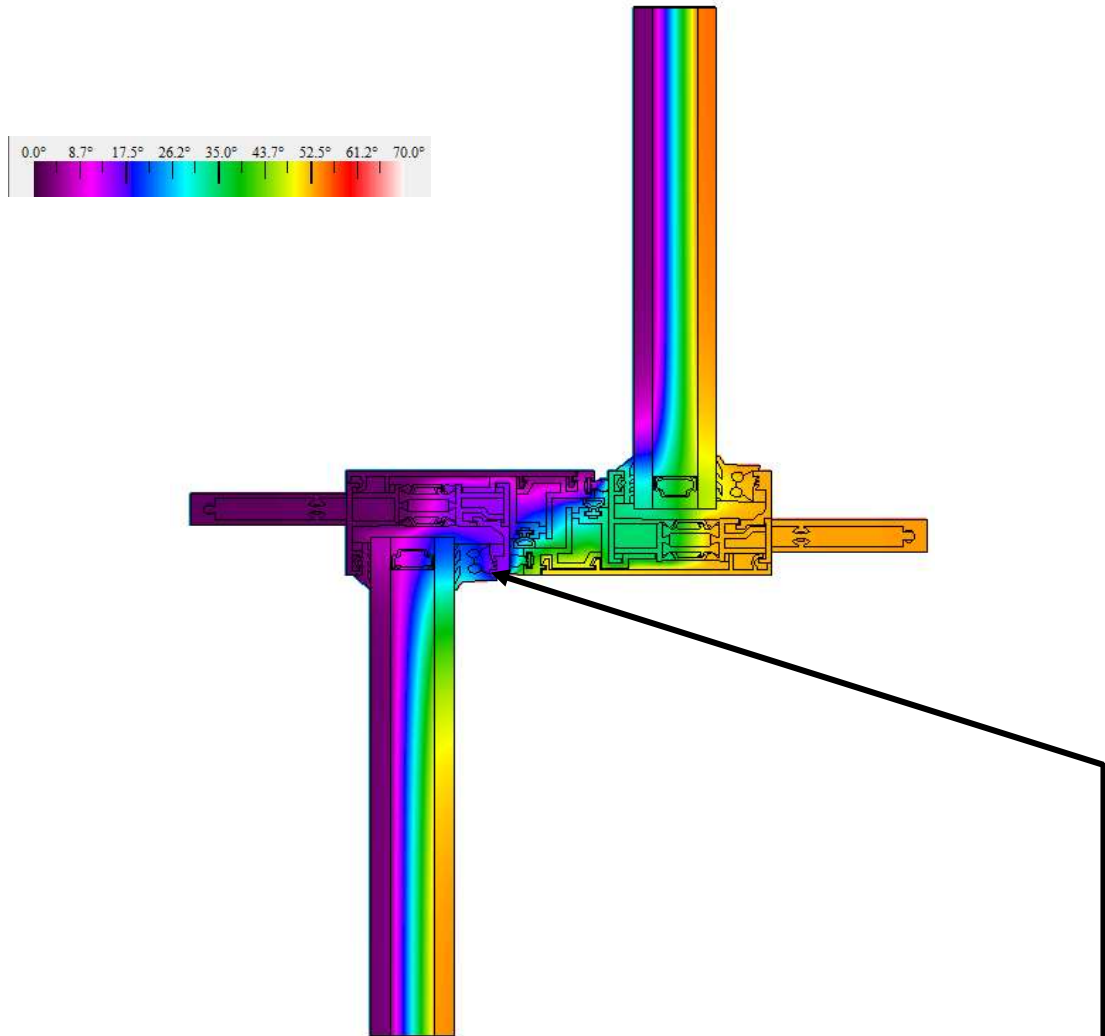

Dewpoint Temperature	37.2°F
Coldest Interior Frame Temperature	15.3°F
Edge of Glass Temperature	38.4°F
Coldest Interior Temperature	15.3°F

TEST REPORT FOR WINDLOCH, LLC

Report No.: P4680.03-116-45 R0

Date: 11/22/22

SECTION 6

SIMULATION RESULTS

DEWPOINT TEMPERATURE ANALYSIS: DEWPOINT LINE PLOT

Cross Section	2/401
Exterior Air Temperature	0°F
Interior Air Temperature	70°F
Relative Humidity	30% RH
Exterior Wind Velocity	12.3 mph

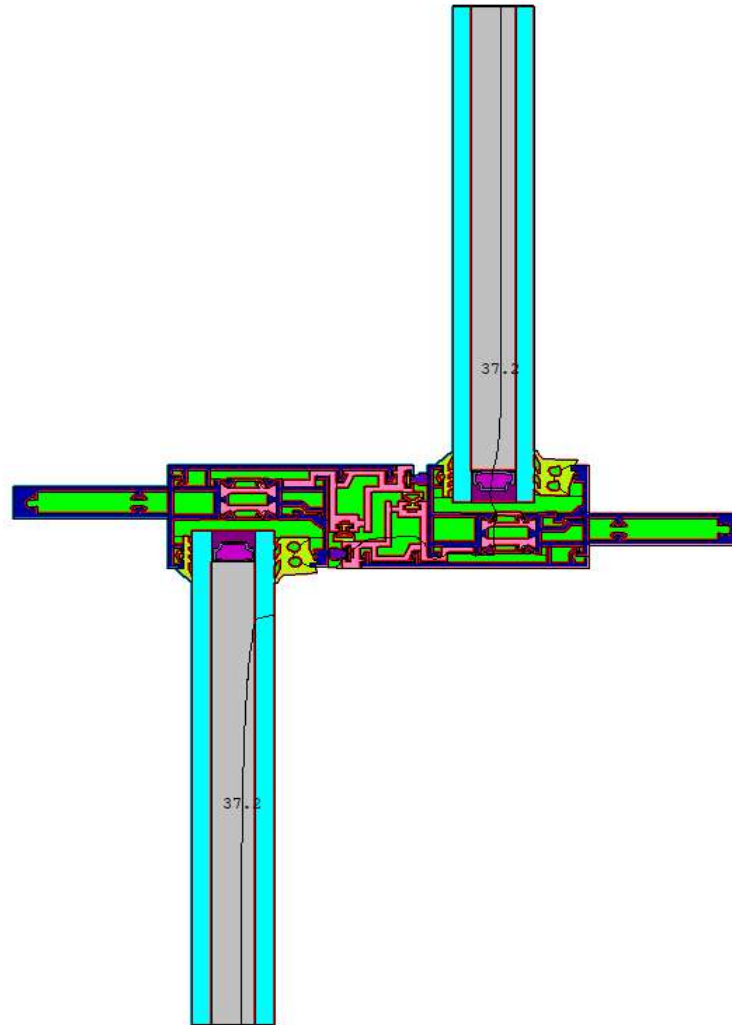

Dewpoint Temperature	37.2°F
Coldest Interior Frame Temperature	15.3°F
Edge of Glass Temperature	38.4°F
Coldest Interior Temperature	15.3°F

TEST REPORT FOR WINDLOCH, LLC

Report No.: P4680.03-116-45 R0

Date: 11/22/22

SECTION 6

SIMULATION RESULTS

DEWPOINT TEMPERATURE ANALYSIS: TEMPERATURE DISTRIBUTION PLOT

Cross Section	3/401
Exterior Air Temperature	0°F
Interior Air Temperature	70°F
Relative Humidity	30% RH
Exterior Wind Velocity	12.3 mph

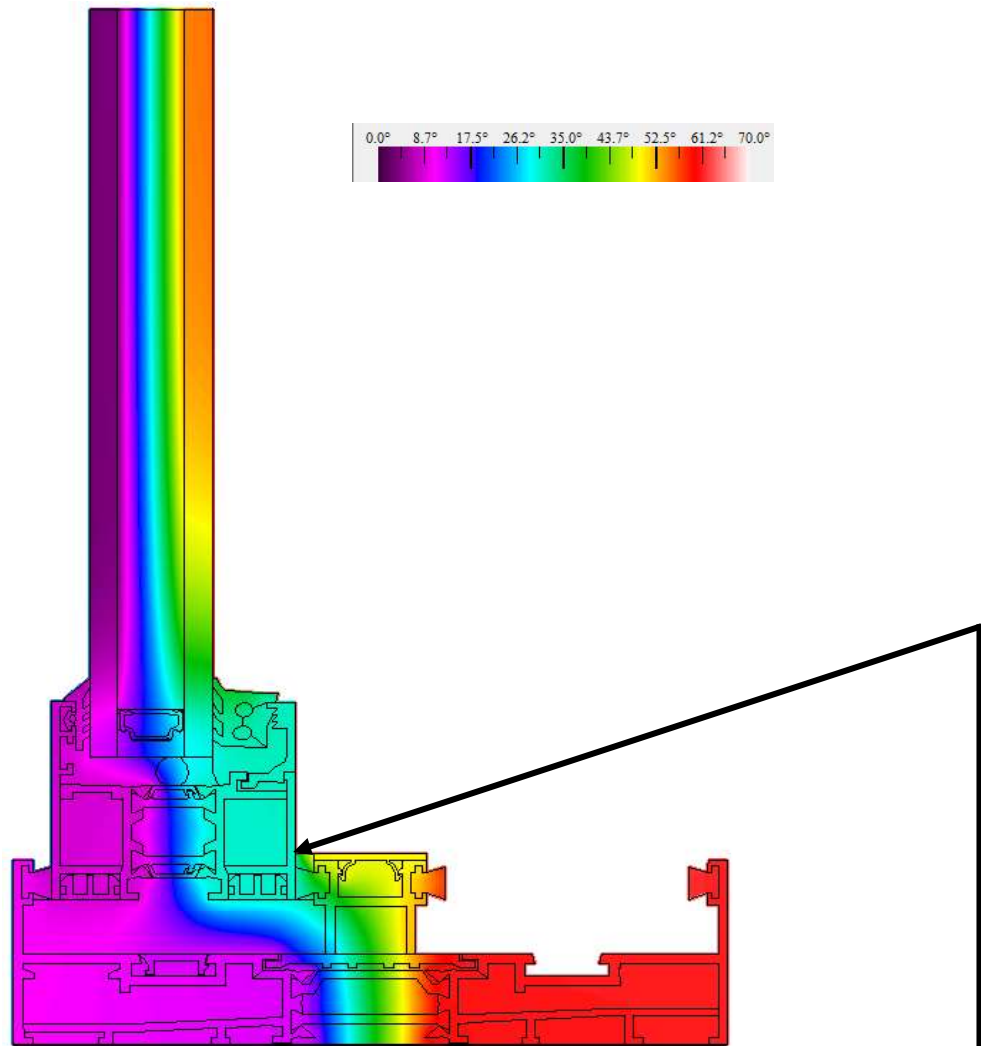

Dewpoint Temperature	37.2°F
Coldest Interior Frame Temperature	30.6°F
Edge of Glass Temperature	43.8°F
Coldest Interior Temperature	30.6°F

TEST REPORT FOR WINDLOCH, LLC

Report No.: P4680.03-116-45 R0

Date: 11/22/22

SECTION 6

SIMULATION RESULTS

DEWPOINT TEMPERATURE ANALYSIS: DEWPOINT LINE PLOT

Cross Section	3/401
Exterior Air Temperature	0°F
Interior Air Temperature	70°F
Relative Humidity	30% RH
Exterior Wind Velocity	12.3 mph

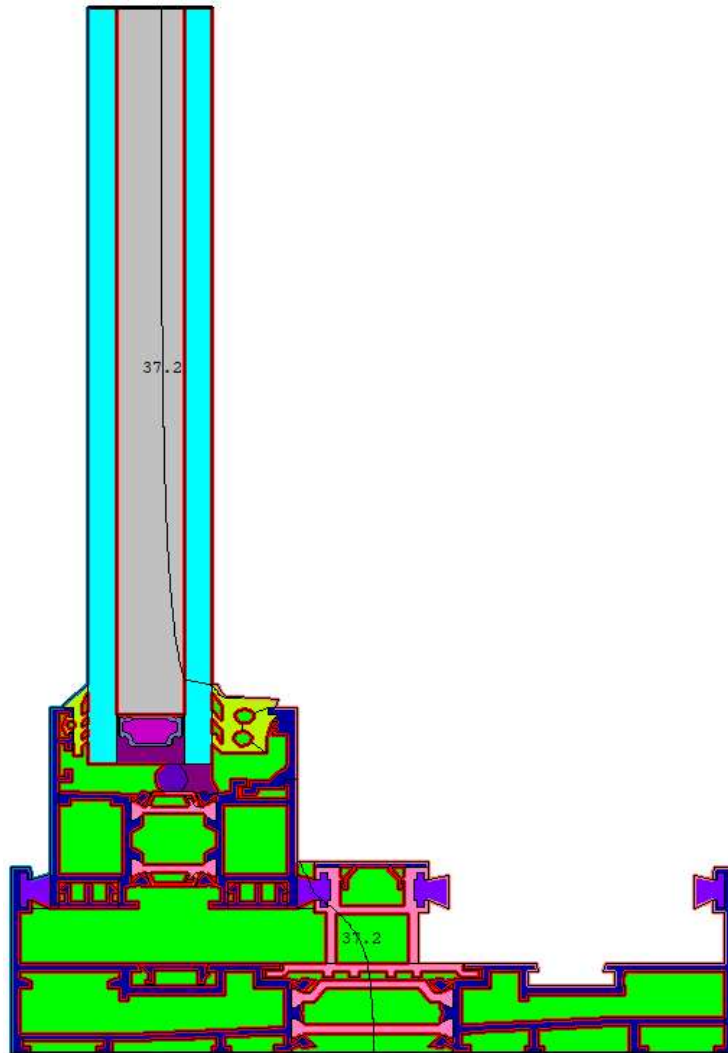

Dewpoint Temperature	37.2°F
Coldest Interior Frame Temperature	30.6°F
Edge of Glass Temperature	43.8°F
Coldest Interior Temperature	30.6°F

TEST REPORT FOR WINDLOCH, LLC

Report No.: P4680.03-116-45 R0

Date: 11/22/22

SECTION 6

SIMULATION RESULTS

DEWPOINT TEMPERATURE ANALYSIS: TEMPERATURE DISTRIBUTION PLOT

Cross Section	1/402
Exterior Air Temperature	0°F
Interior Air Temperature	70°F
Relative Humidity	30% RH
Exterior Wind Velocity	12.3 mph

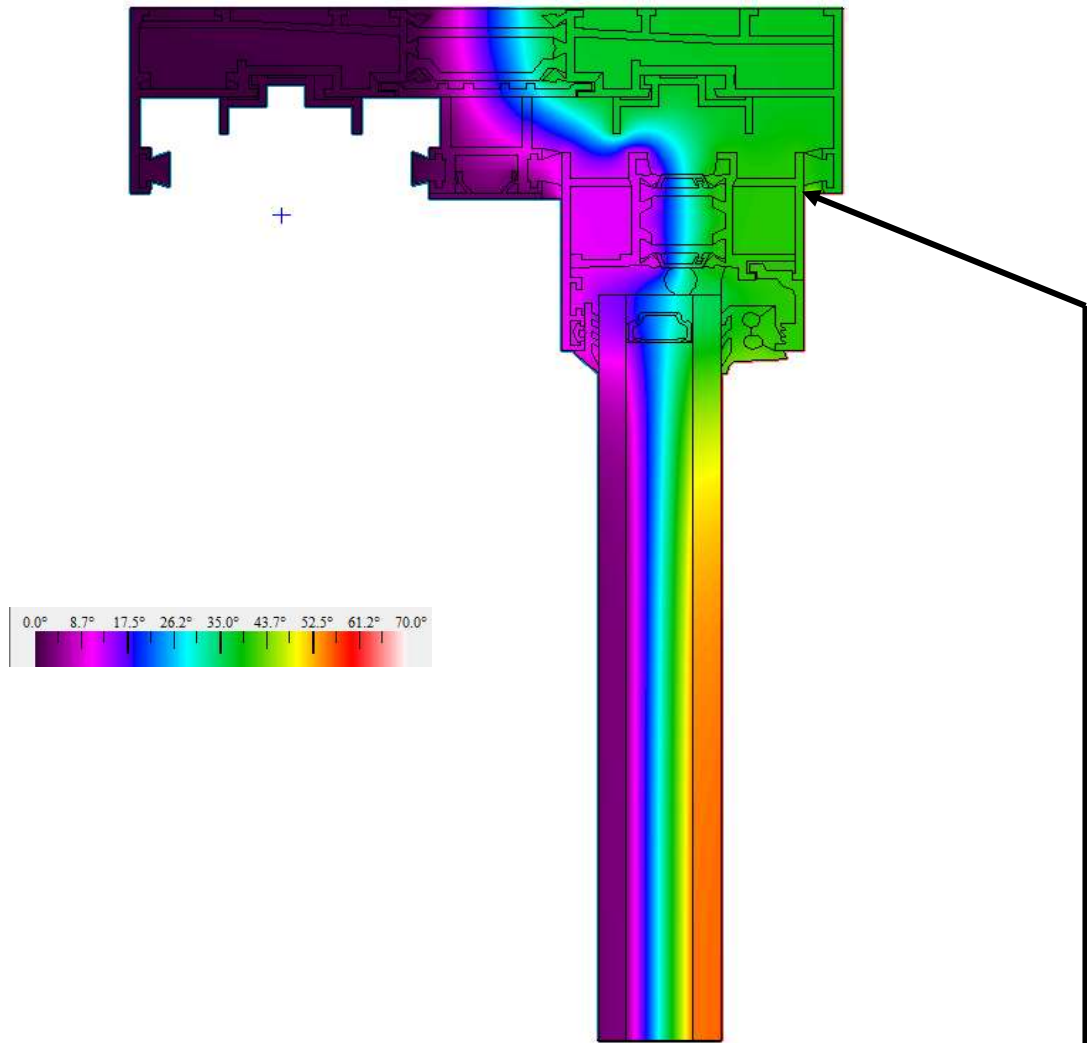

Dewpoint Temperature	37.2°F
Coldest Interior Frame Temperature	40.3°F
Edge of Glass Temperature	47.1°F
Coldest Interior Temperature	40.3°F

TEST REPORT FOR WINDLOCH, LLC

Report No.: P4680.03-116-45 R0

Date: 11/22/22

SECTION 6

SIMULATION RESULTS

DEWPOINT TEMPERATURE ANALYSIS: DEWPOINT LINE PLOT

Cross Section	1/402
Exterior Air Temperature	0°F
Interior Air Temperature	70°F
Relative Humidity	30% RH
Exterior Wind Velocity	12.3 mph

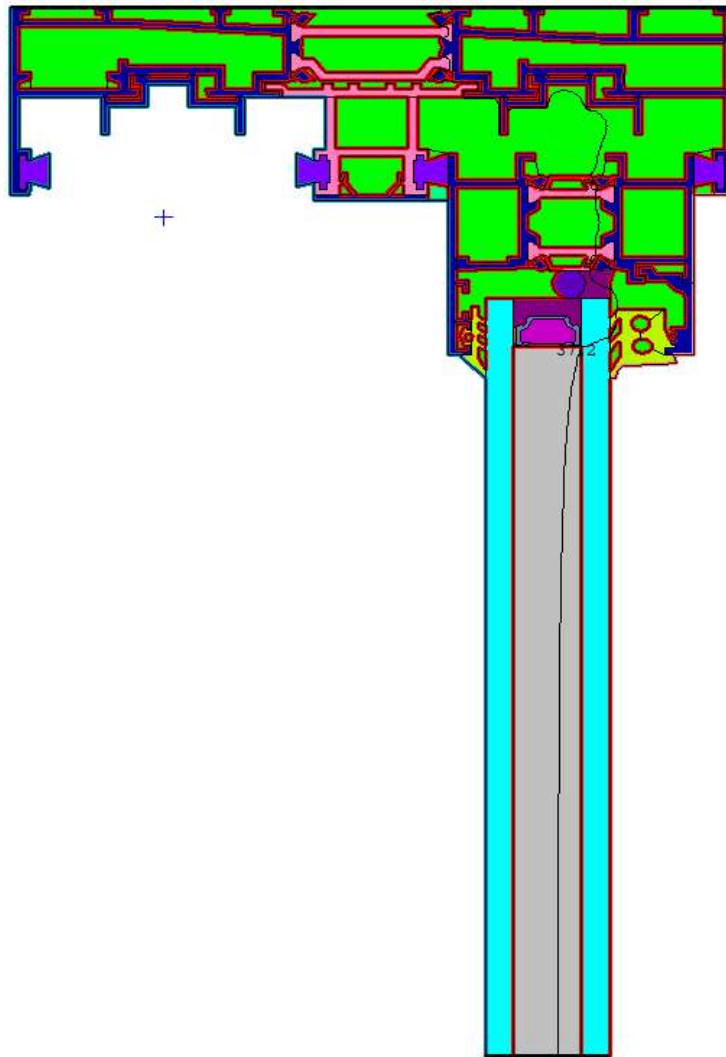

Dewpoint Temperature	37.2°F
Coldest Interior Frame Temperature	40.3°F
Edge of Glass Temperature	47.1°F
Coldest Interior Temperature	40.3°F

TEST REPORT FOR WINDLOCH, LLC

Report No.: P4680.03-116-45 R0

Date: 11/22/22

SECTION 6

SIMULATION RESULTS

DEWPOINT TEMPERATURE ANALYSIS: TEMPERATURE DISTRIBUTION PLOT

Cross Section	3/402
Exterior Air Temperature	0°F
Interior Air Temperature	70°F
Relative Humidity	30% RH
Exterior Wind Velocity	12.3 mph

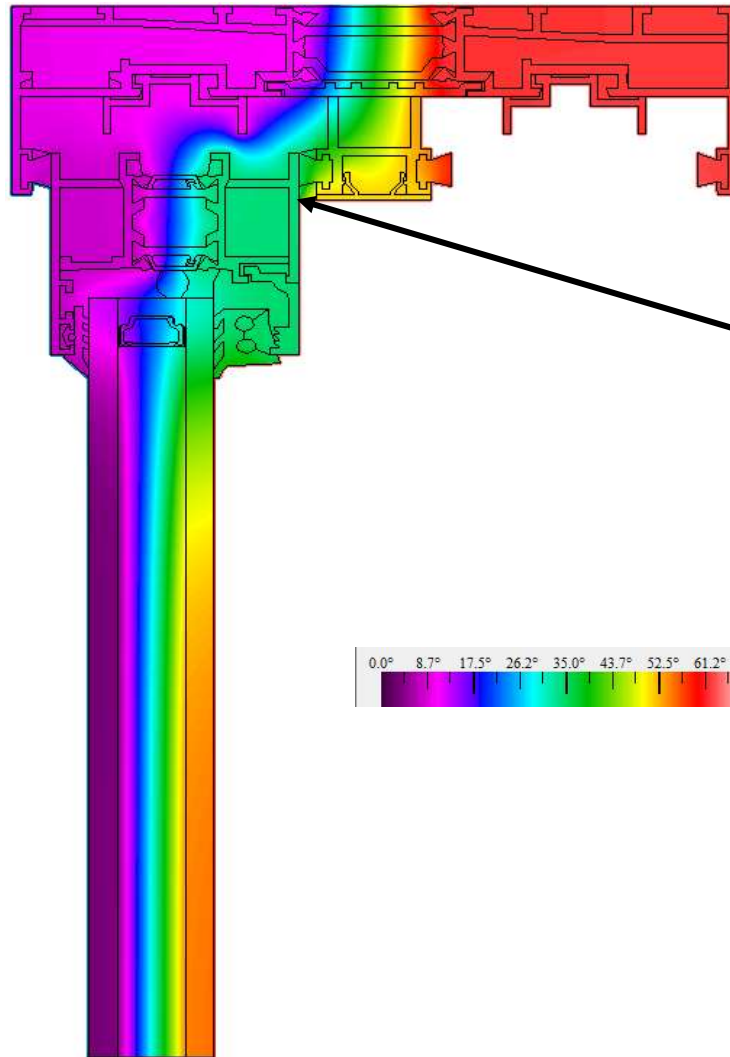

Dewpoint Temperature	37.2°F
Coldest Interior Frame Temperature	34.0°F
Edge of Glass Temperature	44.7°F
Coldest Interior Temperature	34.0°F

TEST REPORT FOR WINDLOCH, LLC

Report No.: P4680.03-116-45 R0

Date: 11/22/22

SECTION 6

SIMULATION RESULTS

DEWPOINT TEMPERATURE ANALYSIS: DEWPOINT LINE PLOT

Cross Section	3/402
Exterior Air Temperature	0°F
Interior Air Temperature	70°F
Relative Humidity	30% RH
Exterior Wind Velocity	12.3 mph

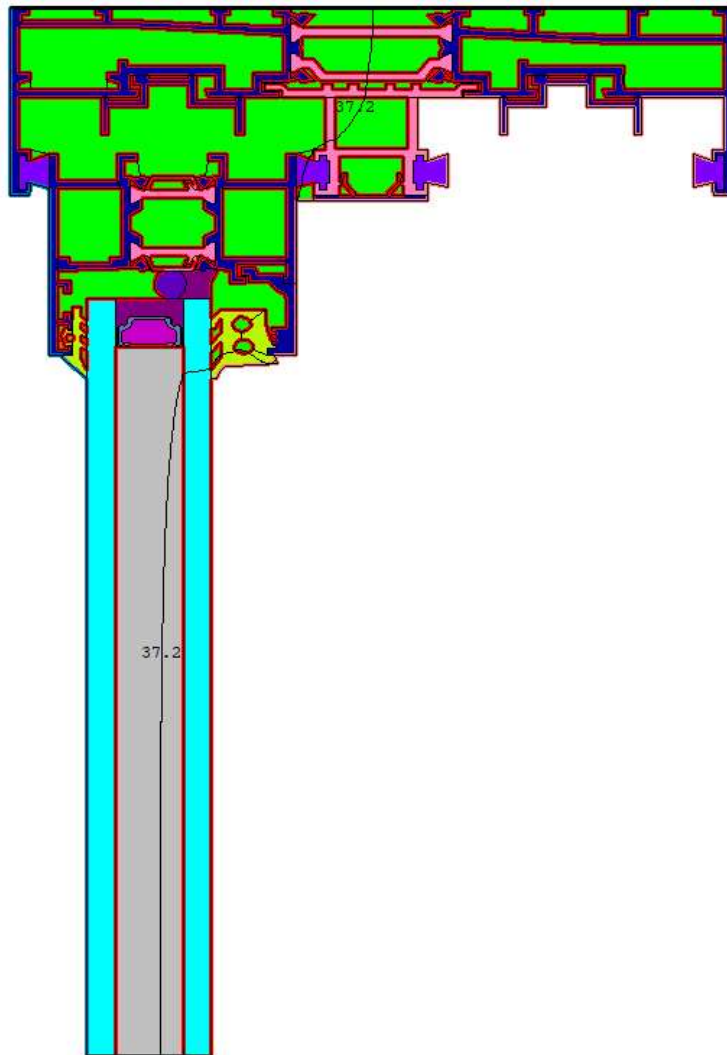

Dewpoint Temperature	37.2°F
Coldest Interior Frame Temperature	34.0°F
Edge of Glass Temperature	44.7°F
Coldest Interior Temperature	34.0°F

TEST REPORT FOR WINDLOCH, LLC

Report No.: P4680.03-116-45 R0

Date: 11/22/22

SECTION 6

SIMULATION RESULTS

DEWPOINT TEMPERATURE ANALYSIS: TEMPERATURE DISTRIBUTION PLOT

Cross Section	4/402
Exterior Air Temperature	0°F
Interior Air Temperature	70°F
Relative Humidity	30% RH
Exterior Wind Velocity	12.3 mph

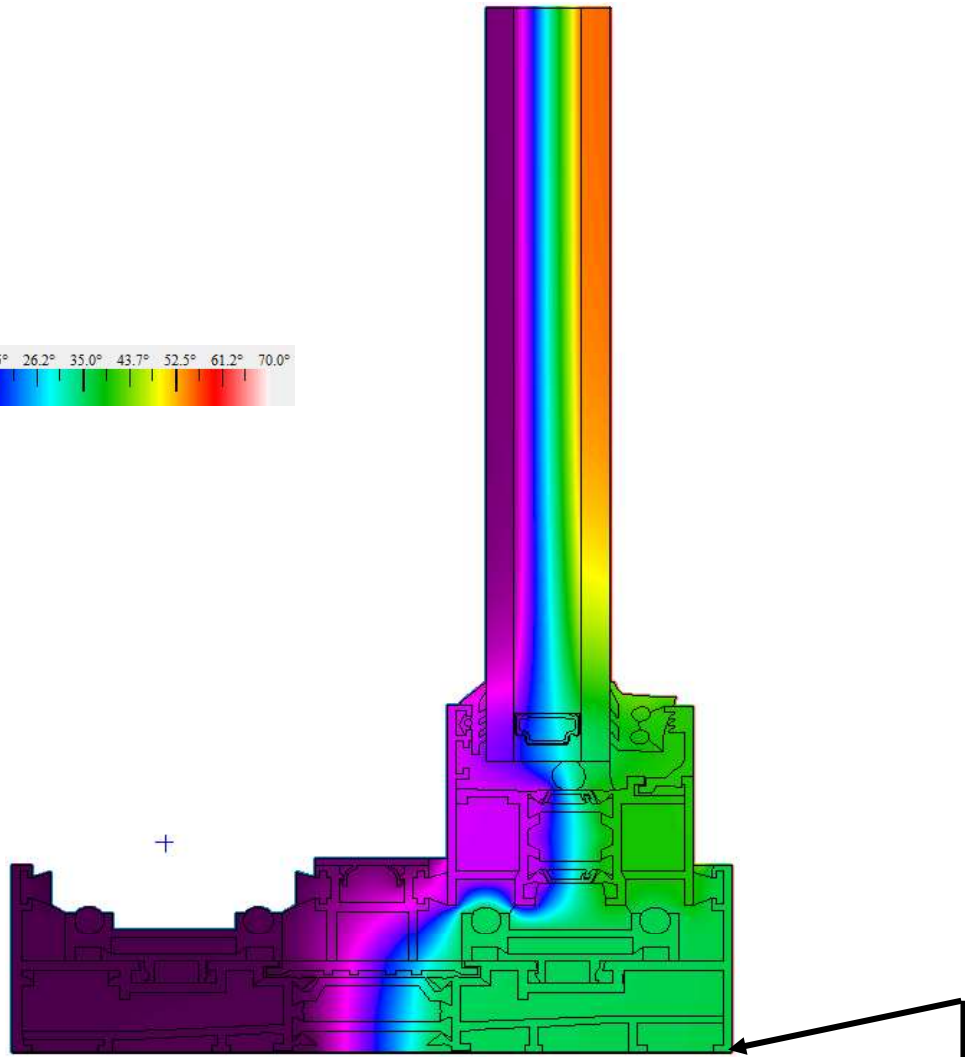
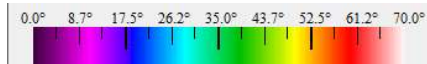

Dewpoint Temperature	37.2°F
Coldest Interior Frame Temperature	36.0°F
Edge of Glass Temperature	47.0°F
Coldest Interior Temperature	36.0°F

TEST REPORT FOR WINDLOCH, LLC

Report No.: P4680.03-116-45 R0

Date: 11/22/22

SECTION 6

SIMULATION RESULTS

DEWPOINT TEMPERATURE ANALYSIS: DEWPOINT LINE PLOT

Cross Section	4/402
Exterior Air Temperature	0°F
Interior Air Temperature	70°F
Relative Humidity	30% RH
Exterior Wind Velocity	12.3 mph

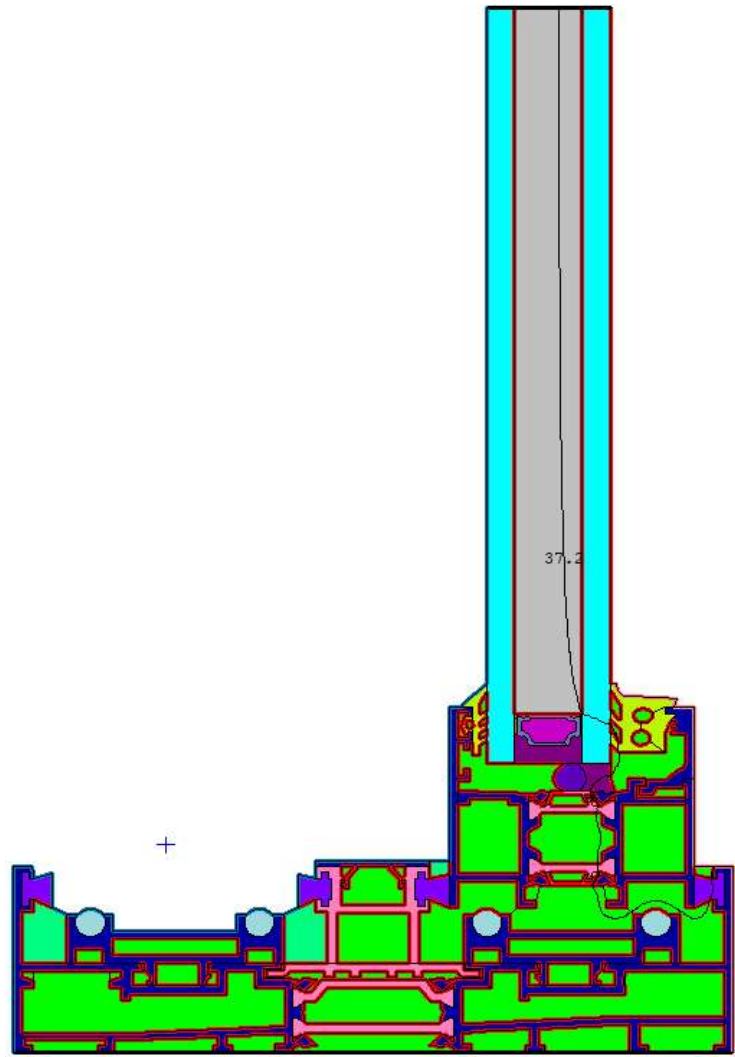

Dewpoint Temperature	37.2°F
Coldest Interior Frame Temperature	36.0°F
Edge of Glass Temperature	47.0°F
Coldest Interior Temperature	36.0°F

TEST REPORT FOR WINDLOCH, LLC

Report No.: P4680.03-116-45 R0

Date: 11/22/22

SECTION 6

SIMULATION RESULTS

DEWPOINT TEMPERATURE ANALYSIS: TEMPERATURE DISTRIBUTION PLOT

Cross Section	5/402
Exterior Air Temperature	0°F
Interior Air Temperature	70°F
Relative Humidity	30% RH
Exterior Wind Velocity	12.3 mph

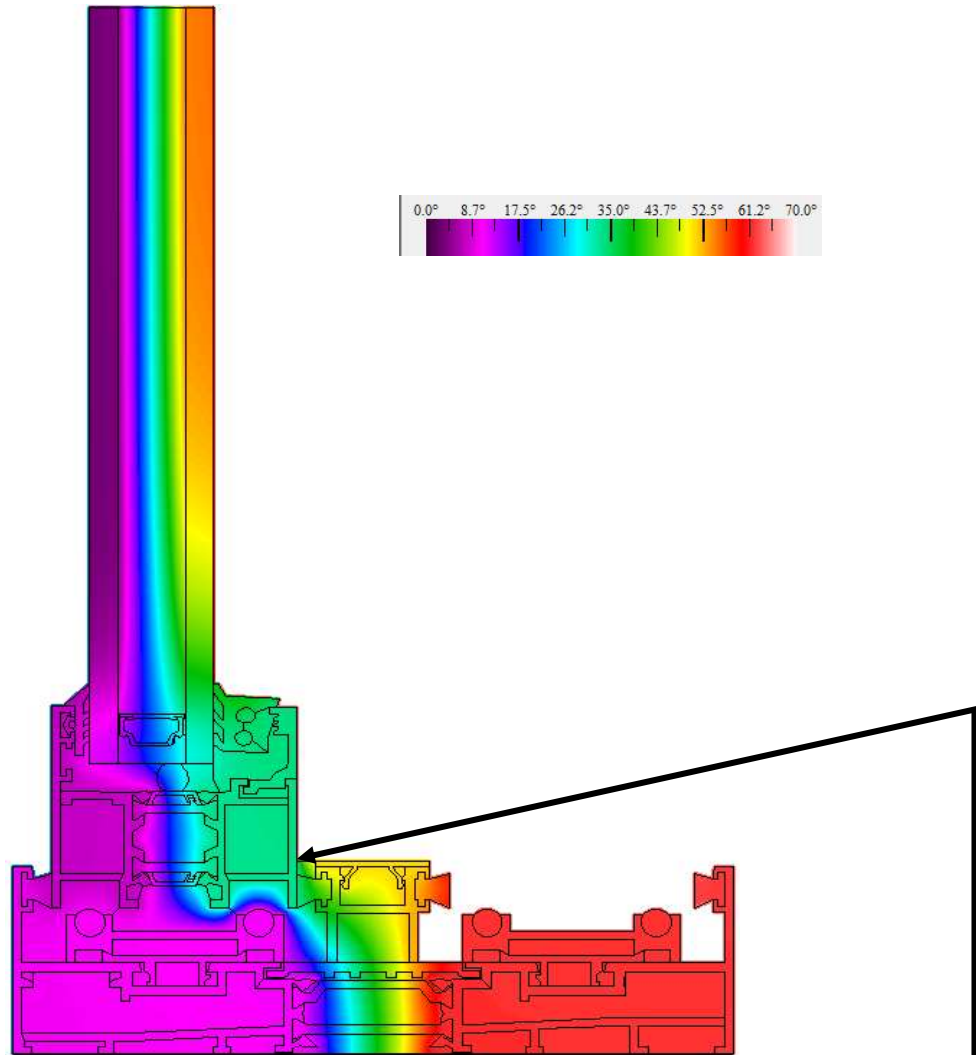

Dewpoint Temperature	37.2°F
Coldest Interior Frame Temperature	33.3°F
Edge of Glass Temperature	44.5°F
Coldest Interior Temperature	33.3°F

TEST REPORT FOR WINDLOCH, LLC

Report No.: P4680.03-116-45 R0

Date: 11/22/22

SECTION 6

SIMULATION RESULTS

DEWPOINT TEMPERATURE ANALYSIS: DEWPOINT LINE PLOT

Cross Section	5/402
Exterior Air Temperature	0°F
Interior Air Temperature	70°F
Relative Humidity	30% RH
Exterior Wind Velocity	12.3 mph

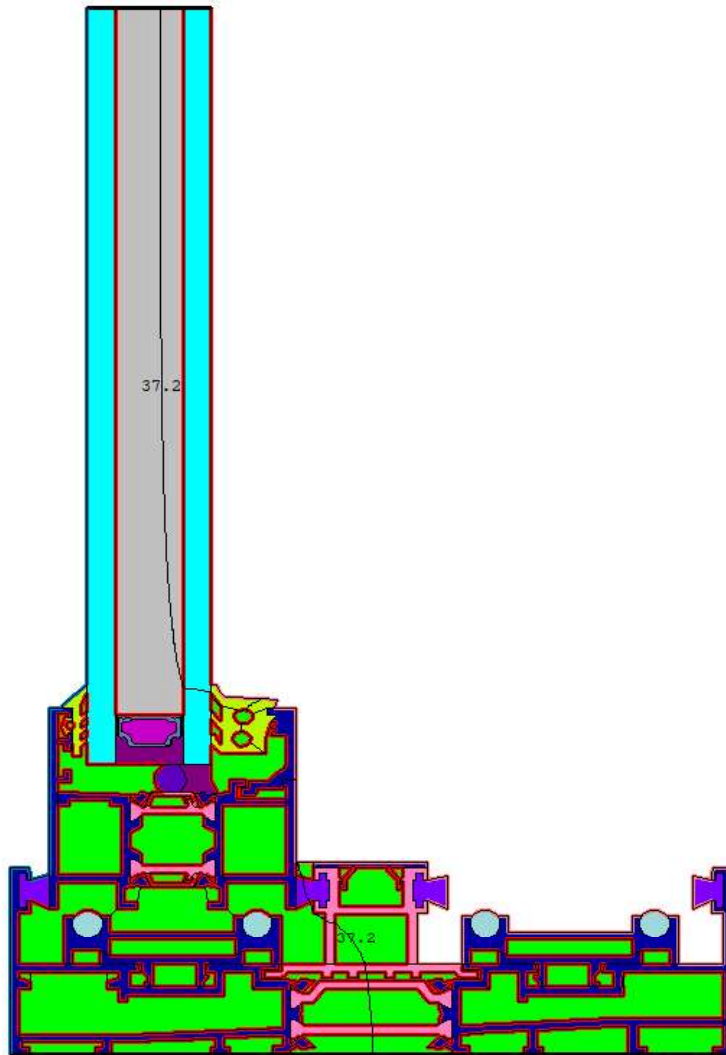

Dewpoint Temperature	37.2°F
Coldest Interior Frame Temperature	33.3°F
Edge of Glass Temperature	44.5°F
Coldest Interior Temperature	33.3°F



Total Quality. Assured.

130 Derry Court
York, PA, 17406

Telephone: 717-764-7700
Facsimile: 717-764-4129
www.intertek.com/building

TEST REPORT FOR WINDLOCH, LLC

Report No.: P4680.03-116-45 R0

Date: 11/22/22

SECTION 7

DRAWINGS / BILL OF MATERIALS / THERM REPORTS*

The drawings which follow have been reviewed by Intertek B&C and are representative of the simulation result(s) reported herein. Any deviations are documented herein or on the drawings.

**THERM Reports available where applicable.*

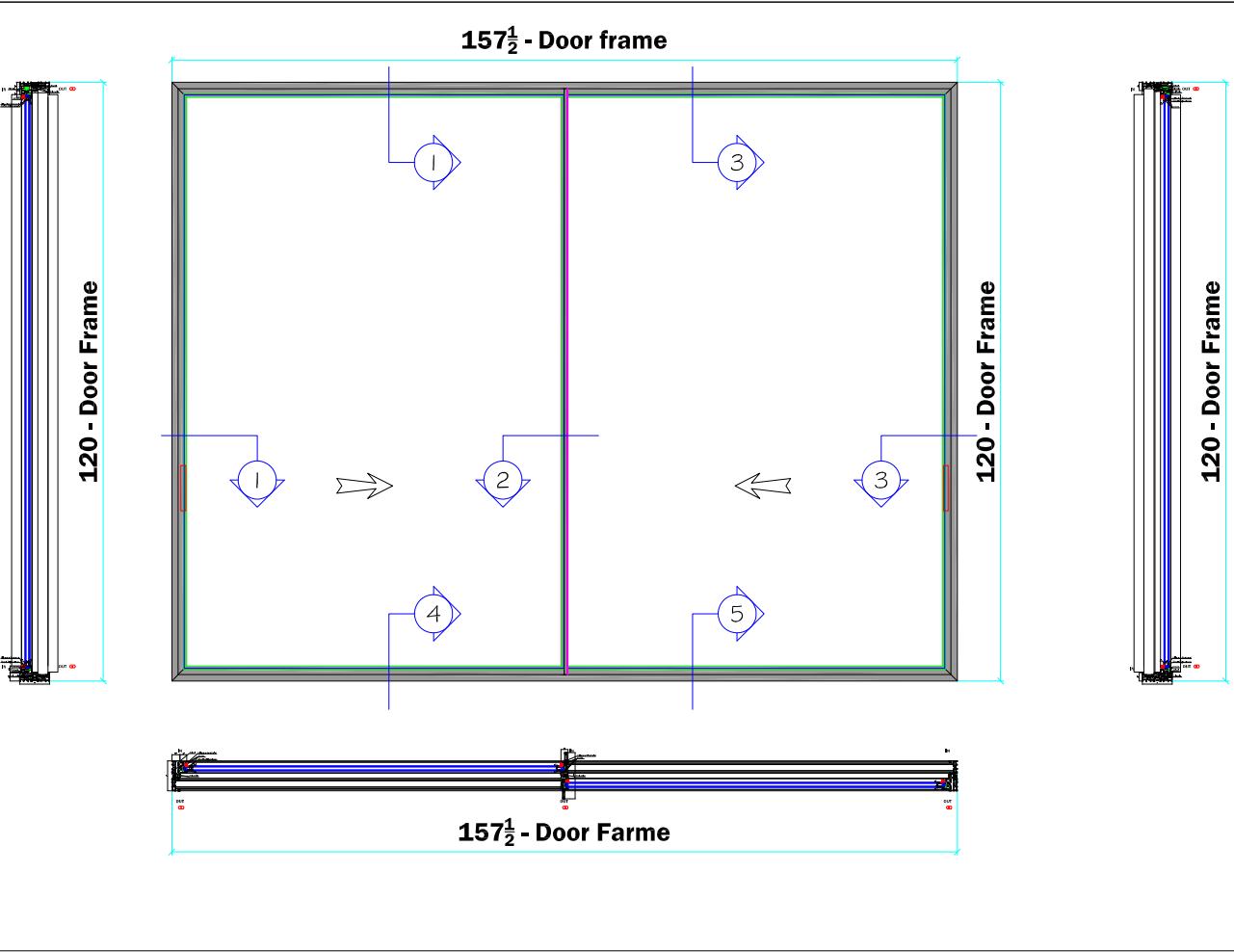

General Notes:

Profiles: Aluminum 6063-T6

Glass:

Option 1:

Outer pane: $\frac{1}{4}$ Solarban 72#2 on Acuity

Spacer: $\frac{9}{16}$ Warm edge with Argon

Inner pane: $\frac{1}{4}$ Acuity

Option 2:

Outer pane: $\frac{1}{4}$ Solarban 60#2 on Clear

Spacer: $\frac{9}{16}$ Warm edge with Argon

Inner pane: $\frac{1}{4}$ Clear

 Report #: P4680-116-45
 Date: 11/22/2022
 Verified by: *[Signature]*

 WINDLOCH 467 Brook Avenue, Unit-C Deer Park, NY 11729 (718)940-8331 (831)940-7745 (941)718-4868 Fax info@windloch.com WWW.WINDLOCH.COM	THESE SHOP DRAWINGS CONTAIN PROPRIETARY INFORMATION OF WINDLOCH LLC. THEY ARE INTENDED SOLELY FOR THE INFORMATION AND USE OF WINDLOCH LLC, AND THE PARTIES MENTIONED HEREIN. SUCH PROPRIETARY INFORMATION MAY NOT BE USED, REPRODUCED OR DISCLOSED TO ANY OTHER PARTIES WITHOUT THE EXPRESSED PERMISSION OF WINDLOCH LLC.	
	PROJECT: LOCATION: ARCHITECT: CONSULTANT: SHEET DESCRIPTION: Sliding Door Minimal 52	DRAWN BY: YOAV BEN-SHIMON SCALE: 1/2"=1' (11x17) DATE: 11/22/22 SHEET NO.: 101

TEST REPORT FOR WINDLOCH, LLC





















Report No.: P4680.03-116-45 R0

Date: 11/22/22

SECTION 8

MATERIALS PROPERTIES LIST

This table outlines approved NFRC 101 Materials, and their associated colors, used to perform these custom simulations. All listed values may be found in NFRC 101-2020 [E1A14]. Any material properties not included on this list are available upon request.

	Material	Conductivity (W/m*K)	Conductivity (Btu*in/h*ft2*F)	Emissivity
	Aluminum Alloys (Painted)	160	1109.36	0.9
	Aluminum Alloys (mill finish)	160	1109.36	0.05
	Brick, Fired clay - medium density	0.74	5.131	0.9
	Butyl rubber (isobutene, solid/hot melt)	0.24	1.664	0.9
	Concrete - medium density	1.15	7.973	0.9
	Coniferous woods (Softwoods)	0.14	0.971	0.9
	Ethylene Propylene Diene Monomer (EPDM)	0.25	1.733	0.9
	Foam Rubber	0.06	0.416	0.9
	Frame Cavity NFRC 100	VARIABLES	VARIABLES	-
	Frame Cavity Slightly Ventilated NFRC 100	VARIABLES	VARIABLES	-
	Glass Fiber (Semi-Rigid) Sheathing	0.034	0.236	0.9
	Gypsum plasterboard	0.16	1.109	0.9
	Mineral Fiber-low density (rock, slag, glass)	0.042	0.291	0.9
	Mohair (polyester) sweep	0.14	0.971	0.9
	Polyamide (PA 66/Nylon - 25% glass fill)	0.30	2.08	0.9
	Polyisobutylene (PIB)	0.20	1.387	0.9
	Expanded Polystyrene (EPS)	0.038	0.263	0.9
	Quanex Building Products Super Spacer TriSeal	0.141	0.978	0.9
	Silicone	0.35	2.427	0.9
	Steel (rolled, ground, plated)	50	346.674	0.2



Total Quality. Assured.

130 Derry Court
York, PA, 17406

Telephone: 717-764-7700
Facsimile: 717-764-4129
www.intertek.com/building

TEST REPORT FOR WINDLOCH, LLC

Report No.: P4680.03-116-45 R0

Date: 11/22/22

SECTION 9

REVISION LOG

REVISION #	DATE	PAGES	REVISION
.01R0	11/22/22	N/A	Original Report Issued to Windloch, LLC.